

COLORADO



LOCAL 321

NATIONAL POSTAL MAIL HANDLERS UNION

Division of the Laborer's International Union of North America,
AFL-CIO

1833 WEST ELK PLACE - DENVER, COLORADO 80211

Office 1-303-455-6400 Fax 1-303-455-5810 Watts 1-800-521-5094 TDD 1-303-455-6400



~~FOR YOUR INFORMATION~~

May 19, 2006

Join the Union, Join the Fight
Membership Drive

Our National and Local 321 membership drives ended on March 31, 2006. As of today we have 7 confirmed members who have signed up a non-member and received bounty payments for \$50. Please join me in thanking those mail handlers listed below who are responsible for signing up a non-member. Each will have 1 entry in the upcoming drawing. The National office has 2 additional unresolved bounty-payments pending; therefore, we will not be drawing the winner of a 27" TV/DVD/VCR as previously scheduled. These entries must first be resolved. **The drawing has been rescheduled for Friday June 30th, 2006 at 2pm at the Union Hall.**

Deb Ensign	Claude Ridley
Bill Scroggin	Cindy Hoehl-Rinker
Leo Carrillo	Don Gonzales
Kevin Kne	

Local 321 Scholarships Awarded

On April 19, 2006 the scholarship committee for Local 321 held the drawing for the \$500 scholarships to be awarded to five applicants for the 2006-2007 school year. This year we had 8 eligible applications in the drawing. The five names that were picked and awarded scholarships are:

NAME	SPONSOR	FACILITY
<i>Amber Armendaraz</i>	<i>Phil Armendaraz</i>	<i>Grand Junction</i>
<i>Danielle Mondragon</i>	<i>Don Mondragon</i>	<i>BMC</i>
<i>Geoffrey Cardenas</i>	<i>Ron Cardenas</i>	<i>Boulder</i>
<i>Matthew Mondragon</i>	<i>Don Mondragon</i>	<i>BMC</i>
<i>Lauren Butts</i>	<i>William Butts</i>	<i>P&DC</i>

Congratulations to all of the winners. This is the eighth straight year Local 321 has sponsored a scholarship program for members and their dependants. Please join me in thanking Don Gonzales and Lorie Farrand from the Scholarship Committee for a job well done.

Evolutionary Network Development Program

Early this year, the Postal Service announced plans to redesign their processing and delivery network when they rolled out the Evolutionary Network Development (E.N.D.) program.

Management cited declining single-piece first-class mail volumes, population shifts, increases in drop shipments by advertising mailers at destinating postal facilities, technological advancements in equipment, network redundancies, and the need for operational flexibility as their reasons. The agencies' goal is to "migrate to a flexible network that increases operational efficiency, reduces costs, and improves consistency of service." Stated as simply as possible, this is a two phase project.

It is comprised of facility consolidations and a redesign of the transportation network. In Colorado, it is believed that we will not be impacted by facility consolidations. We do not have this problem. Modifications in transportation methods will define our changes here.

With the E.N.D. program, the USPS intends to:

- Close over 50 annexes that are temporary plants used for mail processing when space is limited,
- Close over 38 Remote Encoding Centers that assign barcodes to mail pieces from out-of-town locations, and
- Convert BMCs that process and distribute bulk standard mail and parcels to Regional Distribution Centers.

The USPS plans to replace the current existing facility-types with five processing facility-types.

Out With the Old:

Processing & Distribution Centers
Customer Service Facilities
Bulk Mail Centers
Logistic and Distribution Centers
Air Mail Centers
Remote Encoding Centers
International Service Centers
Mail Processing Annexes

In With the New:

<p><u>Regional Distribution Centers</u> RDCs will replace the BMCs and will process all classes of parcels and bundles and serve as Surface Transfer Centers.</p>
<p><u>Local Processing Centers</u> LPCs will process single-piece letters and flats and cancel mail. Our GMFs will become LPCs.</p>
<p><u>Destination Processing Centers</u> DPCs will process single-piece letters and flats.</p>
<p><u>Airport Transfer Centers</u> ATCs will serve as air transfer points.</p>
<p><u>Remote Encoding Centers</u> RECs assign barcodes to mail pieces from remote out-of-town locations.</p>

E.N.D. Implementation and Impact on the Mail Handler Craft

How will E.N.D. be implemented in Colorado and how will it affect the mail handler craft? This is a complicated question that cannot be fully answered right now. I will share what I can, but understand that plans and schedules are constantly changing. Let me start by saying do not panic, do not jump ship, do not bid and do not transfer in haste. The future holds many changes, but after everything shakes out, there will still be plenty of work for the craft in your facility.

The Denver BMC will undergo a major redesign, and will be converted to a Regional Distribution Center (RDC). Much of the BMC mail will be temporarily moved to and worked at the Denver Mail Processing Annex (MPA) during the construction period. This will be a temporary solution to process BMC mail at the MPA during the redesign construction. Both BMC sack-sorters will be removed and replaced with two 200-bin APPS machines. There will certainly be other mail-flow network diversions to reduce Denver BMC volume during construction.

When all is said and done, the BMC *expansion* (which currently houses the APPS machine) will eventually become the Surface Transfer Center hub. It seems likely that the BMC will return to a 3 shift/24-hour facility, but this will not come to fruition for 1-2 years.

This brings us to the MPA. Employees at the MPA will also undergo changes in the next few years. Many details are still sketchy, but the short story is that the MPA will process as much of the BMC's mail as is possible during the BMC redesign construction. When the BMC construction is complete, the Postal Service plans to work all bundles and all parcels in the BMC; this includes priority.

Management is proposing a short-term leased Surface Transfer Center (STC) hub in Aurora, near the MPA during the BMC construction/transition period. This STC Hub will ultimately be moved to the BMC when construction is complete, but the leased facility will ease the temporary burdens placed on the MPA & BMC. This leased facility will accommodate truck movement and dock-connections transfers until the BMC is back on line. As of now, this decision has not been finalized.

What about the GMF you ask. Don't worry; those working at the General Mail Facility will not be left out of the excitement. The Postal Service has already manufactured the next generation of flat sorting machines. That is right; headquarters has already built, tested and scheduled deployment of the replacement machines for the AFSM100's. There will be modifications to the machine, but for our practical purposes, it is in the final stages and will be rolled out soon.

The good news is that the new FSS Flat Sequencing System flat machines will be installed with automated induction (AI), automated tray handling technology (ATHS) and flat preparation stations similar to the modifications being installed on the current AFSM100s. The NPMHU has secured the craft jurisdiction award on this work on the 100s, and these duties will be present on the next generation FSS flat sorters. The FSS utilizes a two-pass system that will sort flats to carrier delivery sequence. This technology will greatly impact the clerk and carrier crafts. Deployment of the new FSS machines (*shown below*) will begin in 2008 and will replace the GMF's current flat sorters. Deployment schedules are unavailable at this time, but you should know they are

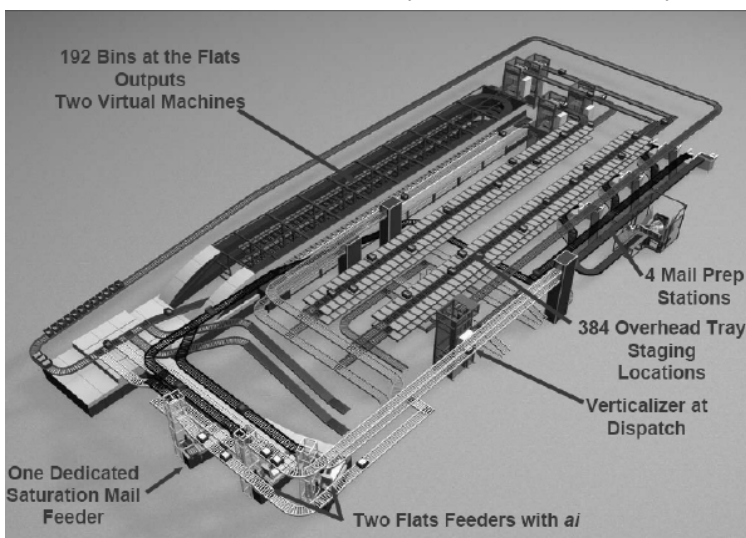

coming to Denver. These E.N.D. program changes and processing equipment upgrades will impact everyone in some way over the next 2 years. Your Union will do everything possible to ensure that everyone stays gainfully employed while attempting to keep disruptions to a minimal. We will do everything contractually possible to protect the craft's rights and interests throughout this transition period. Current information will be posted as it becomes available. Your ongoing support is appreciated.

Local 321 Discusses Key Issues with 7th Congressional District Candidate Ed Perlmutter

By Steve Brown

Legislative and Political Coordinator

Members of the NPMHU Local 321 and members of the American Federation of Government Employees Union met with Congressional candidate Ed Perlmutter on May 4 at our Local headquarters to discuss issues that are important to us as federal workers. Mr. Perlmutter is running in the highly sought-after 7th Congressional district which includes parts of Aurora, Adams county, Lakewood, and Arvada. About one third of Local 321's registered voters live in the 7th district.

This seat is currently held by Bob Beauprez who is stepping down to vie for Governor. Ed Perlmutter showed that he has a strong knowledge of issues affecting workers including privatization, raising the minimum wage, and protecting federal retirement plans. He is a Denver-area native. He was in the Colorado State Senate for 2 terms with an excellent pro-labor record there. This is the first time that I know of that Local 321 has held a formal meeting with a politician in our union hall to let him know we are concerned about politics, and paying attention. With so many changes in the workplace, with Postal Reform in congress, and with attacks on retirement, healthcare, and education, it makes sense to let politicians know we are keeping track of the issues. A comprehensive report on key positions will be included in our upcoming Local Union newsletter.

Upcoming Events

Thursday May 25, 7:00 pm.

Denver Area Labor Federation (DALF) monthly meeting. 140 Sheridan Blvd., Denver.

Meet union members from many trades and learn what labor is doing in and around the metro area.

Saturday June 3, 10:00 am.

Pancake Breakfast with 7th District Democratic Congressional Candidate Ed Perlmutter, & Gubernatorial Candidate Bill Ritter.

Representatives Diane DeGete & Mark Udall will also speak.

Where: 4510 Indiana Street, Golden.

For Additional Information and tickets please call: 303-433-2100-ext5606

Saturday July 22, 2006 Noon

Colorado Mail Handlers Annual Picnic

Where: Lakeside Amusement Park

Additional information will be in our upcoming newsletter and will be posted in all facilities.

In Unity, *Mike*

Michael J Hora
President,
NPMHU Local 321